

SEÇKİN



SEÇKİN
— cooling —

FİRMA TANITIMI

Seçkin Soğutma olarak 1991 yılından bu yana sahip olduğumuz tecrübe ve bilgi birikimini kullanarak müşterilerimize yerinde keşifler ve projelendirme çalışmaları yapmaktayız. İhtiyaçlara uygun son teknoloji ile çalışan entegre sistem projeleri tasarlayarak anahtar teslim hizmet sağlamaktayız. Müşteri memnuniyetini temel ilkimiz kabul ederek, proje öncesi ve sonrası eğitim ve danışmanlık hizmeti de vererek bu amacını en üst kalite ile yerine getirmekteyiz. En iyi hizmeti sunabilmek için müşterileri ile işbirliği yaparak, gerekli olan sistemlerin enerji tasarrufunu da sağlayacak şekilde üretilmesi için en uygun projeleri hazırlamaktayız. Hazırladığımız bu projelerdeki soğuk hava depoları, soğutma sistemleri, soğutucu reyon ve ekipmanlarının en son teknolojiye sahip olmalarına önem vermekteyiz.

VİZYONUMUZ

Türkiye' de ve dünyanın her yerinde yaygın, güvenilir ve aynı kalitede hizmet sunan, müşteri ve insan kaynağını en değerli aktifi olarak kabul eden, sürekli olarak fark ve değer yaratan, rakiplerinin örnek aldığı, her aşamada ve müşteri odaklı çalışan, evrensel, saygın ve piyasa değeri yüksek, bizi biz yapan etik değerlerimizle oluşturduğumuz sağlam zemini her zaman koruyarak şirketimizi büyütmeye devam etmektedir.

MİSYONUMUZ

Müşteri ihtiyaç ve beklentilerini en iyi şekilde anlayarak, onlara en doğru kanaldan en uygun çözüm önerilerini sunan, yaygın servis ağı ile geniş "ürün ve hizmet yelpazesini sektörün her kesimine en hızlı ve en etkin şekilde ulaştıran, etik değerlerinin ve sosyal sorumluluğunun bilincinde olarak, dünya standartlarında sürdürülebilir karlılık ve verimlilikle faaliyet gösteren, müşteri memnuniyetini her şeyden "üstün tutan ve faaliyette bulunduğumuz her alanda kaliteli yükselten bir firma olmaktır.

COMPANY INTRODUCTION

As Seckin Refrigeration we have been making research and project studies for our customers by using our experience and knowledge since 1991. We provide turnkey by designing integrated system projects that work with the latest technology in accordance with the needs. We accept customer satisfaction as our basic principle and improve it with the highest quality by providing training and consultancy services before and after the project. In order to provide the best service, we are preparing the most suitable projects in order to produce the necessary systems in an energy saving manner by cooperating with the customers. We attach importance to the latest technology of cold storage, refrigeration systems, serve-over counters, multideck cabinets and shop and markets equipments.

OUR VISION

To grow our company by providing reliable and high qualified service all around the world, considering customer satisfaction and human resource as most valuable asset, continuous improvement and innovation, exemplified by competitors, customer oriented working style at every stage, universal and highly respected working style with the ethical values.

OUR MISSION

To be a global company by, understanding the needs and expectations of customers in the best way, offering the most appropriate solutions, servicing in fastest and most affective way to all segments of sector with the wide spread network and wide range of products awareness of ethical values and social responsibility operating with sustainable profitability and efficiency, which consider customer satisfaction most valuable asset and increasing the quality in all areas.

PRESENTATION DE LA COMPAGNIE

En tant que Seckin Soğutma, nous effectuons des recherches et des études de projets sur place pour nos clients en profitant de notre expérience et de nos connaissances acquis depuis 1991. Nous fournissons clé en main en concevant des projets de systèmes intégrés et conçus selon les besoins qui fonctionnent avec les dernières technologies. Nous avons adopté comme principe de base la satisfaction clientèle et l'améliorons avec la plus haute qualité en offrant des services de formation et de conseil avant et après le projet. Afin de fournir les meilleurs services, nous préparons les projets les plus appropriés afin de produire les systèmes nécessaires le plus économe sur le plan énergétique tout en coopérant avec nos clients. Nous attachons de l'importance aux dernières technologies en matière d'entreposage frigorifique, de systèmes de réfrigération, de comptoirs de service, d'armoires à plusieurs étages et d'équipements de magasins.

NOTRE VISION

Continuer à développer notre entreprise en fournissant un service fiable et hautement qualifié dans le monde entier, en considérant la satisfaction du client et les ressources humaines comme l'atout le plus précieux, l'amélioration et l'innovation continue qui guident ses concurrents, un style de travail orienté à chaque étape sur la clientèle, un style de travail universel et hautement respecté avec les valeurs éthiques

NOTRE MISSION

Être une entreprise mondiale en comprenant au mieux les besoins et les attentes des clients, en offrant les solutions les plus appropriées, en desservant de la manière la plus rapide et la plus efficace tous les segments du secteur avec un vaste réseau et une large gamme de produits conscients de valeurs d'éthique et responsabilité sociale opérant avec une rentabilité et une efficacité durables, qui considèrent la satisfaction clientèle comme l'atout le plus précieux et être une compagnie qui vie à augmenter la qualité dans tous les domaines.

DAISY DİK CAMLI REYON

Et ve Şarküteri Vitrini / Deli and Meat Showcase



OPSİYONEL ÜRÜNLER

- Kağıtlık
- Kesme tahtası
- Bıçaklık
- Poşetlik
- Ara bölme camı

OPTIONS

- Stainless steel stands twolowel
- Cutting board
- Knife holder
- Holder plastic bags
- Divinding Glass

OPTIONS

- Porte-serviette en acier inoxydable
- Planche à découper
- Porte-couteaux
- Porte sacs plastiques
- Paroi en verre

ÖLÇÜLER

- 625 mm
- 937 mm
- 1250 mm
- 1875 mm
- 2500 mm
- 2812 mm
- 3125 mm
- 3750 mm
- 1350 x 1350 köşe

TEKNİK ÖZELLİKLER

- Dıştan ve içten motor seçeneği
- Fan üfleli soğutma sistemi
- Otomatik defrost
- Dijital gösterge ve termostat
- 40kg/m poliüretan enjeksiyonlu gövde
- Poliüretan enjeksiyonlu yan paneller
- Amortisörlü yukarı doğru açılan sekirit camlar
- Paslanmaz çelik teşhir yüzeyi
- Paslanmaz çelik çalışma tezgahı
- Ayarlanabilen teşhir tavaları
- Buğulanma önleyici fan sistemi
- Dekorasyona uygun RAL renk seçenekleri
- Kapalı tip veya ayaklı dekor
- Paslanmaz 304 kalite
- Şarküteri - et - meze vitrini
- Led lamba

STANDARD FEATURES

- Remote or plug-in choices
- Air ventilated cooling system
- Programmable defrosting with digital thermostat
- 40kg/m polyurethane injection body
- Polyurethane injected side panels
- Tempered curved glass with lift-up system
- Stainless steel display
- Stainless steel working plate
- Adjustable display trays
- Anti-mist system for front glasses by ventilation
- Ral color choices
- Available with closed bottom trimor with legs
- Stainless steel 304
- Led light

CARACTERISTIQUES TECHNIQUES

- Option de moteur à distance ou intégré
- Système de refroidissement ventilé
- Dégivrage programmable
- Indicateur digital avec thermostat
- Corps d'injection de polyuréthane 40kg/m3
- Panneaux latéraux injectés en polyuréthane
- Verre trempé avec système de levage vertical
- Surface de vitrine en acier inoxydable 304
- Plaque de travail en acier inoxydable 304
- Plateaux de vitrine réglables
- Système de ventilation antibuée
- Choix de couleur Ral compatible avec la décoration
- Disponible avec coffre inférieure fermée ou sur piédestal
- Qualité d'acier inoxydable 304
- Vitrine réfrigérée de boucherie et de charcuterie
- Lumière LED

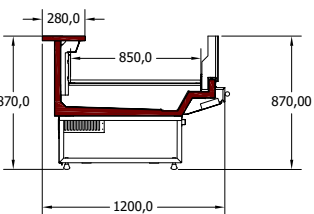
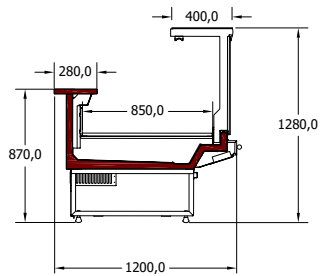

DAISY EĞİK CAMLI REYON Et ve Şarküteri Vitrini / Deli and Meat Showcase



OPSIYONEL ÜRÜNLER

- Kağıtlık
- Kesme tahtası
- Bıçaklık
- Poşetlik
- Ara bölme camı

OPTIONS

- Stainless steel stands twolevel
- Cutting board
- Knife holder
- Holder plastic bags
- Divinding Glass

OPTIONS

- Porte-serviette en acier inoxydable
- Planche à découper
- Porte-couteaux
- Porte sacs plastiques
- Paroi de partition en verre

ÖLÇÜLER

- 625 mm
- 937 mm
- 1250 mm
- 1875 mm
- 2500 mm
- 2812 mm
- 3125 mm
- 3750 mm
- 1350 x 1350 köşe

TEKNİK ÖZELLİKLER

- Dıştan ve içten motor seçeneği
- Fan üfleli soğutma sistemi
- Otomatik defrost
- Dijital gösterge ve termostat
- 40kg/m poliüretan enjeksiyonlu gövde
- Poliüretan enjeksiyonlu yan paneller
- Amortisörlü yukarı doğru açılan sekurit camlar
- Paslanmaz çelik teşhir yüzeyi
- Paslanmaz çelik çalışma tezgahı
- Ayarlanabilen teşhir tavaları
- Buğulanma önleyici fan sistemi
- Dekorasyona uygun RAL renk seçenekleri
- Kapalı tip veya ayaklı dekor
- Paslanmaz 304 kalite
- Şarküteri - et - meze vitrini
- Led lamba

STANDARD FEATURES

- Remote or plug-in choices
- Air ventilated cooling system
- Programmable defrosting with digital thermostat
- 40kg/m polyurethane injection body
- Polyurethane injected side panels
- Tempered curved glass with lift-up system
- Stainless steel display
- Stainless steel working plate
- Adjustable display trays
- Anti-mist system for front glasses by ventilation
- Ral color choices
- Available with closed bottom trimor with legs
- Stainless steel 304
- Led light

CARACTERISTIQUES TECHNIQUES

- Option de moteur à distance ou intégré
- Système de refroidissement ventilé
- Dégivrage programmable
- Indicateur digital avec thermostat
- Corps d'injection de polyuréthane 40kg/m3
- Panneaux latéraux injectés en polyuréthane
- Verre trempé avec système de levage vertical
- Surface de vitrine en acier inoxydable 304
- Plaque de travail en acier inoxydable 304
- Plateaux de vitrine réglables
- Système de ventilation antibuée
- Choix de couleur Ral compatible avec la décoration
- Disponible avec coffre inférieure fermée ou sur piédestal
- Qualité d'acier inoxydable 304
- Vitrine réfrigérée de boucherie et de charcuterie
- Lumière LED

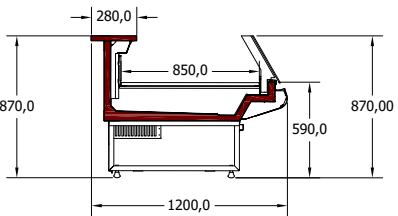
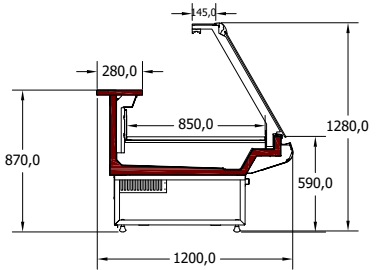

DAISY BOMBE CAMLI SERVİS REYON

Et ve Şarküteri Vitrini / Deli and Meat Showcase



OPSİYONEL ÜRÜNLER

- Kağıtlık
- Kesme tahtası
- Bıçaklık
- Poşetlik
- Ara bölme camı

OPTIONS

- Stainless steel stands twolowel
- Cutting board
- Knife holder
- Holder plastic bags
- Divinding Glass

OPTIONS

- Porte-serviette en acier inoxydable
- Planche à découper
- Porte-couteaux
- Porte sacs plastiques
- Paroi de partition en verre

ÖLÇÜLER

- 625 mm
- 937 mm
- 1250 mm
- 1875 mm
- 2500 mm
- 2812 mm
- 3125 mm
- 3750 mm
- 1350 x 1350 köşe

TEKNİK ÖZELLİKLER

- Diştan ve içten motor seçeneği
- Fan üfleli soğutma sistemi
- Otomatik defrost
- Dijital gösterge ve termostat
- 40kg/m poliüretan enjeksiyonlu gövde
- Poliüretan enjeksiyonlu yan paneller
- Amortisörlü yukarı doğru açılan sekurit camlar
- Paslanmaz çelik teşhir yüzeyi
- Paslanmaz çelik çalışma tezgahı
- Ayarlanabilen teşhir tavaları
- Buğulanma önleyici fan sistemi
- Dekorasyona uygun RAL renk seçenekleri
- Kapalı tip veya ayaklı dekor
- Paslanmaz 304 kalite
- Şarküteri - et - meze vitrini
- Led lamba

STANDARD FEATURES

- Remote or plug-in choices
- Air ventilated cooling system
- Programmable defrosting with digital thermostat
- 40kg/m polyurethane injection body
- Polyurethane injected side panels
- Tempered curved glass with lift-up system
- Stainless steel display
- Stainless steel working plate
- Adjustable display trays
- Anti-mist system for front glasses by ventilation
- Ral color choices
- Available with closed bottom trimor with legs
- Led light

CARACTERISTIQUES TECHNIQUES

- Option de moteur à distance ou intégré
- Système de refroidissement ventilé
- Dégivrage programmable
- Indicateur digital avec thermostat
- Corps d'injection de polyuréthane 40kg/m3
- Panneaux latéraux injectés en polyuréthane
- Verre trempé avec système de levage vertical
- Surface de vitrine en acier inoxydable 304
- Plaque de travail en acier inoxydable 304
- Plateaux de vitrine réglables
- Système de ventilation antibuée
- Choix de couleur Ral compatible avec la décoration
- Disponible avec coffre inférieure fermée ou sur piédestal
- Qualité d'acier inoxydable 304
- Vitrine réfrigérée de boucherie et de charcuterie
- Lumière LED

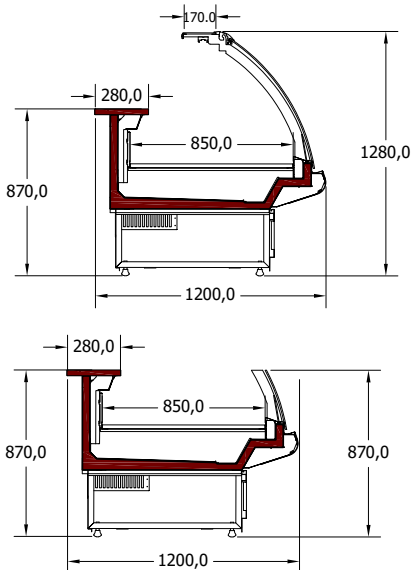

DAISY BOMBE DK90 REYON

Et ve Şarküteri Vitrini / Deli and Meat Showcase



OPSİYONEL ÜRÜNLER

- Kağıtlık
- Kesme tahtası
- Bıçaklık
- Poşetlik
- Ara bölme camı

OPTIONS

- Stainless steel stands twolowel
- Cutting board
- Knife holder
- Holder plastic bags
- Divinding Glass

OPTIONS

- Porte-serviette en acier inoxydable
- Planche à découper
- Porte-couteaux
- Porte sacs plastiques
- Paroi de partition en verre

ÖLÇÜLER

- 625 mm
- 937 mm
- 1250 mm
- 1875 mm
- 2500 mm
- 2812 mm
- 3125 mm
- 3750 mm
- 1350 x 1350 köşe

TEKNİK ÖZELLİKLER

- Dıştan ve içten motor seçeneği
- Fan üfleli soğutma sistemi
- Otomatik defrost
- Dijital gösterge ve termostat
- 40kg/m poliüretan enjeksiyonlu gövde
- Poliüretan enjeksiyonlu yan paneller
- Amortisörlü yukarı doğru açılan sekurit camlar
- Paslanmaz çelik teşhir yüzeyi
- Paslanmaz çelik çalışma tezgahı
- Ayarlanabilen teşhir tavaları
- Buğulanma önleyici fan sistemi
- Dekorasyona uygun RAL renk seçenekleri
- Kapalı tip veya ayaklı dekor
- Paslanmaz 304 kalite
- Şarküteri - et - meze vitrini
- Led lamba

STANDARD FEATURES

- Remote or plug-in choices
- Air ventilated cooling system
- Programmable defrosting with digital thermostat
- 40kg/m polyurethane injection body
- Polyurethane injected side panels
- Tempered curved glass with lift-up system
- Stainless steel display
- Stainless steel working plate
- Adjustable display trays
- Anti-mist system for front glasses by ventilation
- Ral color choices
- Available with closed bottom trimor with legs
- Led light

CARACTERISTIQUES TECHNIQUES

- Option de moteur à distance ou intégré
- Système de refroidissement ventilé
- Dégivrage programmable
- Indicateur digital avec thermostat
- Corps d'injection de polyuréthane 40kg/m³
- Panneaux latéraux injectés en polyuréthane
- Verre trempé avec système de levage vertical
- Surface de vitrine en acier inoxydable 304
- Plaque de travail en acier inoxydable 304
- Plateaux de vitrine réglables
- Système de ventilation antibuée
- Choix de couleur Ral compatible avec la décoration
- Disponible avec coffre inférieure fermée ou sur piédestal
- Qualité d'acier inoxydable 304
- Vitrine réfrigérée de boucherie et de charcuterie
- Lumière LED

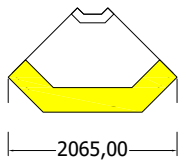
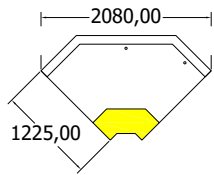

DAISY BOMBE DEVİRME CAMLI REYON

Et ve Şarküteri Vitrini / Deli and Meat Showcase



OPSİYONEL ÜRÜNLER

- Kağıtlık
- Kesme tahtası
- Bıçaklık
- Poşetlik
- Ara bölme camı

OPTIONS

- Stainless steel stands twolowel
- Cutting board
- Knife holder
- Holder plastic bags
- Divinding Glass

OPTIONS

- Porte-serviette en acier inoxydable
- Planche à découper
- Porte-couteaux
- Porte sacs plastiques
- Paroi de partition en verre

ÖLÇÜLER

- 625 mm
- 937 mm
- 1250 mm
- 1875 mm
- 2500 mm
- 2812 mm
- 3125 mm
- 3750 mm
- 1350 x 1350 köşe

TEKNİK ÖZELLİKLER

- Dıştan ve içten motor seçeneği
- Fan üfleli soğutma sistemi
- Otomatik defrost
- Dijital gösterge ve termostat
- 40kg/m poliüretan enjeksiyonlu gövde
- Poliüretan enjeksiyonlu yan paneller
- Paslanmaz çelik çalışma tezgahı
- Ayarlanabilen teşhir tavaları
- Buğulanma önleyici fan sistemi
- Dekorasyona uygun RAL renk seçenekleri
- Kapalı tip veya ayaklı dekor
- Paslanmaz 304 kalite
- Şarküteri - et - meze vitrini
- Led lamba

STANDARD FEATURES

- Remote or plug-in choices
- Air ventilated cooling system
- Programmable defrosting with digital thermostat
- 40kg/m polyurethane injection body
- Polyurethane injected side panels
- Tempered curved glass with lift-up system
- Stainless steel display
- Stainless steel working plate
- Adjustable display trays
- Anti-mist system for front glasses by ventilation
- Ral color choices
- Available with closed bottom trimor with legs
- Led light

CARACTERISTIQUES TECHNIQUES

- Option de moteur à distance ou intégré
- Système de refroidissement ventilé
- Dégivrage programmable
- Indicateur digital avec thermostat
- Corps d'injection de polyuréthane 40kg/m3
- Panneaux latéraux injectés en polyuréthane
- Verre trempé avec système de levage vertical
- Surface de vitrine en acier inoxydable 304
- Plaque de travail en acier inoxydable 304
- Plateaux de vitrine réglables
- Système de ventilation antibuée
- Choix de couleur Ral compatible avec la décoration
- Disponible avec coffre inférieure fermée ou sur piédestal
- Qualité d'acier inoxydable 304
- Vitrine réfrigérée de boucherie et de charcuterie
- Lumière LED

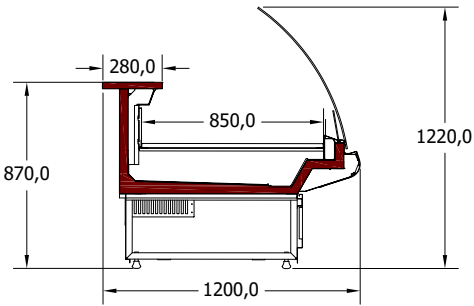

DAISY BOMBE BLOK AYAKLI REYON

Et ve Şarküteri Vitrini / Deli and Meat Showcase



OPSİYONEL ÜRÜNLER

- Kağıtlık
- Kesme tahtası
- Bıçaklık
- Poşetlik
- Ara bölme camı

OPTIONS

- Stainless steel stands twolowel
- Cutting board
- Knife holder
- Holder plastic bags
- Divinding Glass

OPTIONS

- Porte-serviette en acier inoxydable
- Planche à découper
- Porte-couteaux
- Porte sacs plastiques
- Paroi de partition en verre

ÖLÇÜLER

- 625 mm
- 937 mm
- 1250 mm
- 1875 mm
- 2500 mm
- 2812 mm
- 3125 mm
- 3750 mm
- 1350 x 1350 köşe

TEKNİK ÖZELLİKLER

- Dıştan ve içten motor seçeneği
- Fan üfleli soğutma sistemi
- Otomatik defrost
- Dijital gösterge ve termostat
- 40kg/m poliüretan enjeksiyonlu gövde
- Poliüretan enjeksiyonlu yan paneller
- Amortisörlü yukarı doğru açılan sekurit camlar
- Paslanmaz çelik teşhir yüzeyi
- Paslanmaz çelik çalışma tezgahı
- Ayarlanabilen teşhir tavaları
- Buğulanma önleyici fan sistemi
- Dekorasyona uygun RAL renk seçenekleri
- Kapalı tip veya ayaklı dekor
- Paslanmaz 304 kalite
- Şarküteri - et - meze vitrini
- Led lamba

STANDARD FEATURES

- Remote or plug-in choices
- Air ventilated cooling system
- Programmable defrosting with digital thermostat
- 40kg/m polyurethane injection body
- Polyurethane injected side panels
- Tempered curved glass with lift-up system
- Stainless steel display
- Stainless steel working plate
- Adjustable display trays
- Anti-mist system for front glasses by ventilation
- Ral color choices
- Available with closed bottom trimor with legs
- Led light

CARACTERISTIQUES TECHNIQUES

- Option de moteur à distance ou intégré
- Système de refroidissement ventilé
- Dégivrage programmable
- Indicateur digital avec thermostat
- Corps d'injection de polyuréthane 40kg/m³
- Panneaux latéraux injectés en polyuréthane
- Verre trempé avec système de levage vertical
- Surface de vitrine en acier inoxydable 304
- Plaque de travail en acier inoxydable 304
- Plateaux de vitrine réglables
- Système de ventilation antibuée
- Choix de couleur Ral compatible avec la décoration
- Disponible avec coffre inférieure fermée ou sur piédestal
- Qualité d'acier inoxydable 304
- Vitrine réfrigérée de boucherie et de charcuterie
- Lumière LED

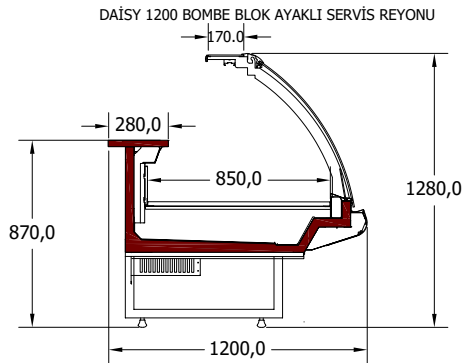

JASMİNE MANAV

Soğutmalı Manav/ Refrigerated Greengrocer



TEKNİK ÖZELLİKLER

- Dıştan motorlu
- 40kg/m³ poliüretan enjeksiyonlu gövde
- Dijital gösterge, termostatlı ve otomatik defrostlu
- Paslanmaz çelik teşhir tavalı
- İthal gece perdeli
- PVC ön tampon koruyuculu
- 2 sıra raflı
- Bütün raflarda eşit hava dağılımı
- Ral seçenekleri
- Raf altı aydınlatması (opsiyonel)
- Ürün yansıtıcı aynalı

STANDARD FEATURES

- Remote wall case
- Air ventilated cooling system
- 40kg/m polyurethane injection body
- Stainless steel display
- Programmable defrosting with digital thermostat
- Manual night blind for energy saving
- PVC bumper for protection
- Equal airflow between the shelves
- Adjustable 2 shelf
- Ral color choices

CARACTERISTIQUES TECHNIQUES

- Corps d'injection de polyuréthane 40kg/m³
- Indicateur digital avec thermostat et dégivrage programmable
- Base de vitrine en acier inoxydable 304
- Rideau de nuit manuel
- Protection avant en PVC
- 2 étagères (la 3ème étagère est optionnelle)
- Dispersion d'air égale entre toutes les étagères
- Options de couleur RAL
- Application en bloc
- Eclairage sous-étagère (Optionnel)
- Miroir reflétant les produits

JASMINE 2050/90

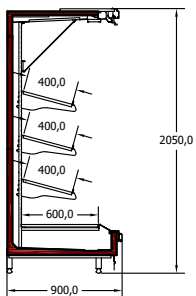

JASMINE 2050/100

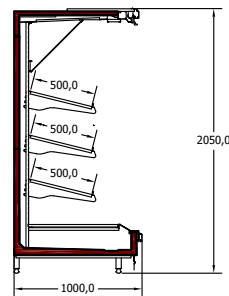

JASMINE 2200/90

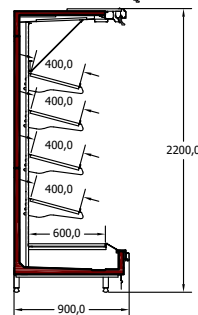

JASMINE 2200/100

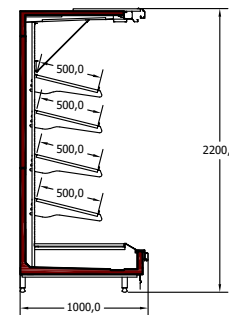

ÖLÇÜLER

- 937 mm
- 1250 mm
- 1875 mm
- 2500 mm
- 2812 mm
- 3125 mm
- 3750 mm



TEKNİK ÖZELLİKLER

- Dıştan motorlu
- 40kg/m³ poliüretan enjeksiyonlu gövde
- Dijital gösterge, termostatlı ve otomatik defrostlu
- Paslanmaz çelik teşhir tavali
- İthal gece perdeli
- PVC ön tampon koruyuculu
- 2 sıra raflı
- Bütün raflarda eşit hava dağılımı
- Ral seçenekleri
- Ada uygulaması
- Raf altı aydınlatması (opsiyonel)

STANDARD FEATURES

- Remote wall case
- Air ventilated cooling system
- 40kg/m polyurethane injection body
- Stainless steel display
- Programmable defrosting with digital thermostat
- Manual night blind for energy saving
- PVC bumper for protection
- Equal airflow between the shelves
- Adjustable 2 shelf
- Ral color choices
- Sliding door choices

CARACTERISTIQUES TECHNIQUES

- Moteur à distance
- Corps d'injection de polyuréthane 40kg/m³
- Indicateur digital avec thermostat et dégivrage programmable
- Base de vitrine en acier inoxydable 304
- Rideau de nuit manuel
- Protection avant en PVC
- 2 étagères
- Dispersion d'air égale entre toutes les étagères
- Options de couleur RAL
- Application en bloc
- Eclairage sous-étagère (Optionnel)

ÖLÇÜLER

- 937 mm
- 1250 mm
- 1875 mm
- 2500 mm
- 2812 mm
- 3125 mm
- 3750 mm

JASMINE KISA SÜTLÜK 1800

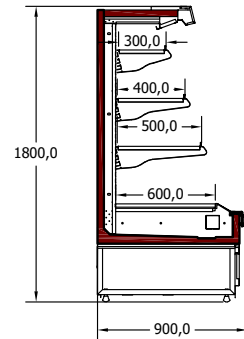

JASMINE KISA SÜTLÜK 1550

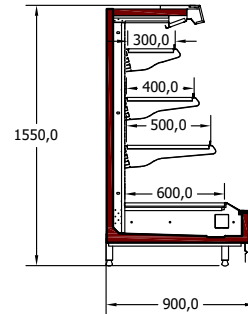

JASMİNE KISA SÜTLÜK ÇERÇEVELİ

Süt Ürünleri / Milk Products



TEKNİK ÖZELLİKLER

- Dıştan motorlu
- 40kg/m³ poliüretan enjeksiyonlu gövde
- Dijital gösterge, termostatlı ve otomatik defrostlu
- Paslanmaz çelik teşhir tavali
- İthal gece perdeli
- PVC ön tampon koruyuculu
- 2 sıra raflı
- Bütün raflarda eşit hava dağılımı
- Ral seçenekleri
- Ada uygulaması
- Raf altı aydınlatması (opsiyonel)

STANDARD FEATURES

- Remote wall case
- Air ventilated cooling system
- 40kg/m polyurethane injection body
- Stainless steel display
- Programmable defrosting with digital thermostat
- Manual night blind for energy saving
- PVC bumper for protection
- Equal airflow between the shelves
- Adjustable 2 shelf
- Ral color choices
- Sliding door choices

CARACTERISTIQUES TECHNIQUES

- Moteur à distance
- Corps d'injection de polyuréthane 40kg/m³
- Indicateur digital avec thermostat et dégivrage programmable
- Base de vitrine en acier inoxydable 304
- Rideau de nuit manuel
- Protection avant en PVC
- 2 étagères
- Dispersion d'air égale entre toutes les étagères
- Options de couleur RAL
- Application en bloc
- Eclairage sous-étagère (Optionnel)

ÖLÇÜLER

- 937 mm
- 1250 mm
- 1875 mm
- 2500 mm
- 2812 mm
- 3125 mm
- 3750 mm

JASMİNE KISA SÜTLÜK 1550 ÇERÇEVELİ

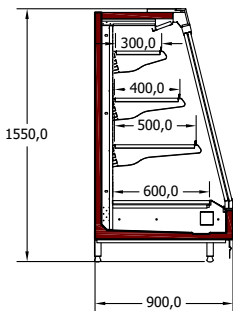

JASMİNE KISA SÜTLÜK 1800 ÇERÇEVELİ

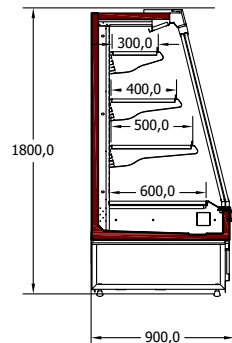



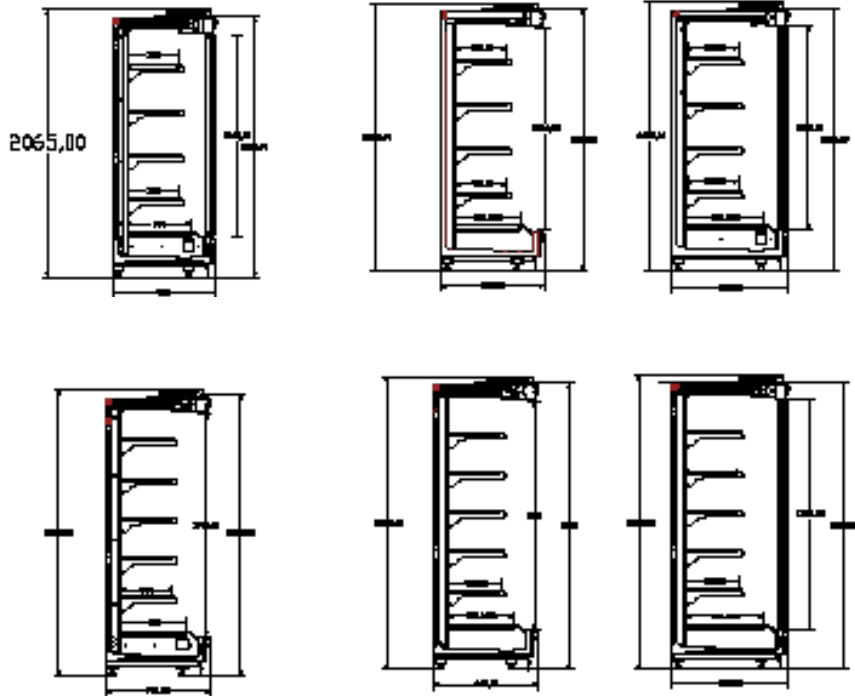

TEKNİK ÖZELLİKLER

- Dıştan ve içten motorlu
- 40kg/m³ poliüretan enjeksiyonlu gövde
- Dijital gösterge, termostatlı ve otomatik defrostlu
- Paslanmaz çelik teşhir tavalı
- İthal gece perdeli
- PVC ön tampon koruyuculu
- 4 sıra raflı
- Bütün raflarda eşit hava dağılımı
- Ral seçenekleri
- Ada uygulaması
- Raf altı aydınlatması (opsiyonel)

STANDARD FEATURES

- Remote or plug-in wall case
- Air ventilated cooling system
- 40kg/m polyurethane injection body
- Stainless steel display
- Programmable defrosting with digital thermostat
- Manual night blind for energy saving
- PVC bumper for protection
- Equal airflow between the shelves
- Adjustable 4 line shelf
- Ral color choices
- Sliding door choices

CARACTERISTIQUES TECHNIQUES

- Option de moteur à distance ou intégré
- Corps d'injection de polyuréthane 40kg/m³
- Indicateur digital avec thermostat et dégivrage programmable
- Base de vitrine en acier inoxydable 304
- Rideau de nuit manuel
- Protection avant en PVC
- 4 étagères
- Dispersion d'air égale entre toutes les étagères
- Options de couleur RAL
- Application en bloc
- Eclairage sous-étagère (Optionnel)

ÖLÇÜLER

- 937 mm
- 1250 mm
- 1875 mm
- 2500 mm
- 2812 mm
- 3125 mm
- 3750 mm



JASMİNE SÜTLÜK ÇERÇEVELİ

Süt Ürünleri / Milk Products

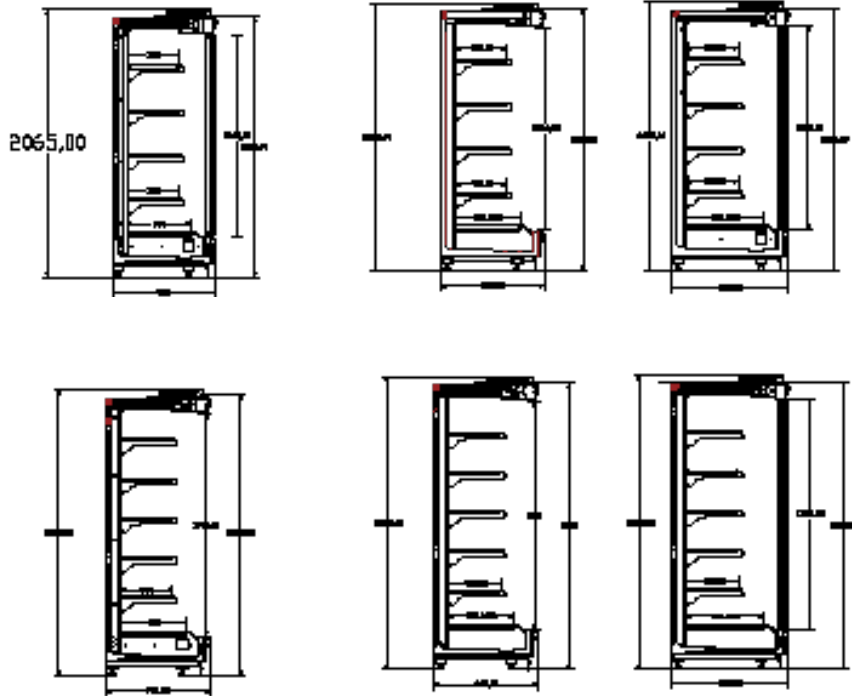

TEKNİK ÖZELLİKLER

- Dıştan ve içten motorlu
- 40kg/m³ poliüretan enjeksiyonlu gövde
- Dijital gösterge, termostatlı ve otomatik defrostlu
- Paslanmaz çelik teşhir tavalı
- İthal gece perdeli
- PVC ön tampon koruyuculu
- 4 sıra raflı
- Bütün raflarda eşit hava dağılımı
- Ral seçenekleri
- Ada uygulaması
- Raf altı aydınlatması (opsiyonel)

STANDARD FEATURES

- Remote or plug-in wall case
- Air ventilated cooling system
- 40kg/m polyurethane injection body
- Stainless steel display
- Programmable defrosting with digital thermostat
- Manual night blind for energy saving
- PVC bumper for protection
- Equal airflow between the shelves
- Adjustable 4 line shelf
- Ral color choices
- Sliding door choices

CARACTERISTIQUES TECHNIQUES

- Option de moteur à distance ou intégré
- Corps d'injection de polyuréthane 40kg/m³
- Indicateur digital avec thermostat et dégivrage programmable
- Base de vitrine en acier inoxydable 304
- Rideau de nuit manuel
- Protection avant en PVC
- 4 étagères
- Dispersion d'air égale entre toutes les étagères
- Options de couleur RAL
- Application en bloc
- Eclairage sous-étagère (Optionnel)

ÖLÇÜLER

- 937 mm
- 1250 mm
- 1875 mm
- 2500 mm
- 2812 mm
- 3125 mm
- 3750 mm



ÖLÇÜLER

- 937 mm
- 1250 mm
- 1875 mm
- 2500 mm
- 2812 mm
- 3125 mm
- 3750 mm

TEKNİK ÖZELLİKLER

- Dıştan motorlu
- 40kg/m³ poliüretan enjeksiyonlu gövde
- Dijital gösterge, termostatlı ve otomatik defrostlu
- Paslanmaz çelik teşhir tavali
- İthal gece perdeli
- PVC ön tampon koruyuculu
- 2 sıra raflı
- Bütün raflarda eşit hava dağılımı
- Ral seçenekleri
- Raf altı aydınlatması (opsiyonel)
- Ürün yansıtıcı aydınlı

STANDARD FEATURES

- Remote wall case
- Air ventilated cooling system
- 40kg/m³ polyurethane injection body
- Stainless steel display
- Programmable defrosting with digital thermostat
- Manual night blind for energy saving
- PVC bumper for protection
- Equal airflow between the shelves
- Adjustable 2 shelf
- Ral color choices

CARACTERISTIQUES TECHNIQUES

- Moteur à distance
- Corps d'injection de polyuréthane 40kg/m³
- Indicateur digital avec thermostat et dégivrage programmable
- Base de vitrine en acier inoxydable 304
- Rideau de nuit manuel
- Protection avant en PVC
- 2 étagères (la 3ème étagère est optionnelle)
- Dispersion d'air égale entre toutes les étagères
- Options de couleur RAL
- Eclairage sous-étagère (Optionnel)
- Miroir reflétant les produits

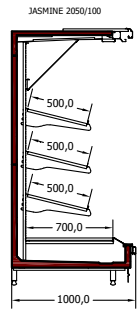
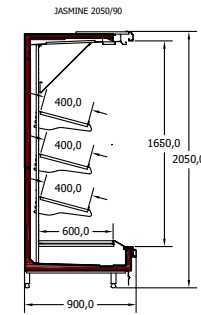
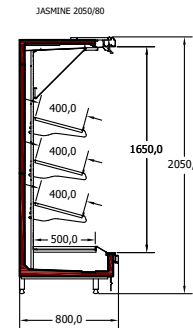
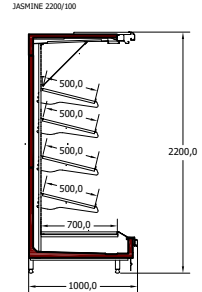
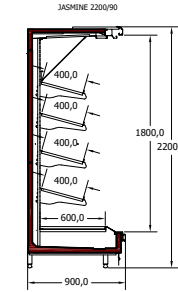
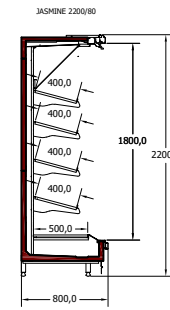

JASMINE 70 SÜTLÜK

Süt Ürünleri / Milk Products



TEKNİK ÖZELLİKLER

- Dıştan ve içten motorlu
- 40kg/m³ poliüretan enjeksiyonlu gövde
- Dijital gösterge, termostatlı ve otomatik defrostlu
- Paslanmaz çelik teşhir tavali
- İthal gece perdeli
- PVC ön tampon koruyuculu
- 5 sıra raflı
- Bütün raflarda eşit hava dağılımı
- Ral seçenekleri
- Ada uygulaması
- Raf altı aydınlatması (opsiyonel)

STANDARD FEATURES

- Remote or plug-in wall case
- Air ventilated cooling system
- 40kg/m polyurethane injection body
- Stainless steel display
- Programmable defrosting with digital thermostat
- Manual night blind for energy saving
- PVC bumper for protection
- Equal airflow between the shelves
- Adjustable 5 line shelf
- Ral color choices
- Sliding door choices

CARACTERISTIQUES TECHNIQUES

- Moteur à distance ou moteur intégré
- Corps d'injection de polyuréthane 40kg/m³
- Indicateur digital avec thermostat et dégivrage programmable
- Base de vitrine en acier inoxydable 304
- Rideau de nuit manuel
- Protection avant en PVC
- 5 étagères
- Dispersion d'air égale entre toutes les étagères
- Options de couleur RAL
- Application et disposition en bloc
- Eclairage sous-étagère (Optionnel)

ÖLÇÜLER

- 937 mm
- 1250 mm
- 1875 mm
- 2500 mm
- 2812 mm
- 3125 mm
- 3750 mm

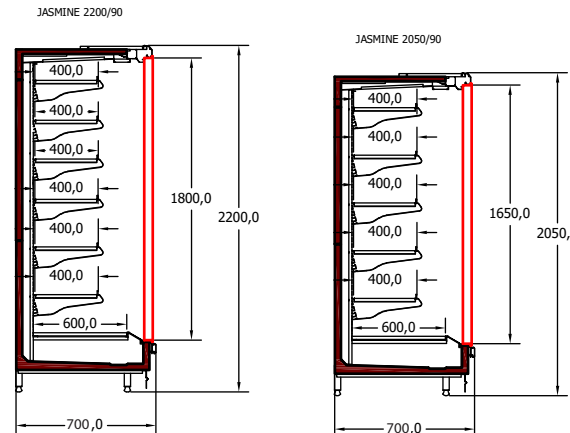



TEKNİK ÖZELLİKLER

- Dıştan ve içten motorlu
- 40kg/m³ poliüretan enjeksiyonlu gövde
- Dijital gösterge, termostatlı ve otomatik defrostlu
- Paslanmaz çelik teşhir tavalı
- İthal gece perdeli
- PVC ön tampon koruyuculu
- 5 sıra raflı
- Bütün raflarda eşit hava dağılımı
- Ral seçenekleri
- Ada uygulaması
- Raf altı aydınlatması (opsiyonel)

STANDARD FEATURES

- Remote or plug-in wall case
- Air ventilated cooling system
- 40kg/m polyurethane injection body
- Stainless steel display
- Programmable defrosting with digital thermostat
- Manual night blind for energy saving
- PVC bumper for protection
- Equal airflow between the shelves
- Adjustable 5 line shelf
- Ral color choices
- Sliding door choices

CARACTERISTIQUES TECHNIQUES

- Moteur à distance ou moteur intégré
- Corps d'injection de polyuréthane 40kg/m³
- Indicateur digital avec thermostat et dégivrage programmable
- Base de vitrine en acier inoxydable 304
- Rideau de nuit manuel
- Protection avant en PVC
- 5 étagères
- Dispersion d'air égale entre toutes les étagères
- Options de couleur RAL
- Application et disposition en bloc
- Eclairage sous-étagère (Optionnel)

ÖLÇÜLER

- 937 mm
- 1250 mm
- 1875 mm
- 2500 mm
- 2812 mm
- 3125 mm
- 3750 mm

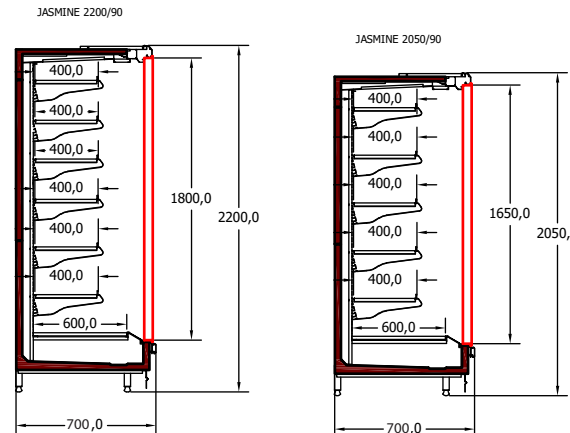

JASMINE PLUG-IN

Süt Ürünleri / Milk Products



TEKNİK ÖZELLİKLER

- İçten motorlu
- 40kg/m³ poliüretan enjeksiyonlu gövde
- Dijital gösterge, termostatlı ve otomatik defrostlu
- Paslanmaz çelik teşhir tavali
- İthal gece perdeli
- PVC ön tampon koruyuculu
- 5 sıra raflı
- Bütün raflarda eşit hava dağılımı
- Ral seçenekleri
- Ada uygulaması
- Raf altı aydınlatması (opsiyonel)

STANDARD FEATURES

- Plug-in
- Air ventilated cooling system
- 40kg/m polyurethane injection body
- Stainless steel display
- Programmable defrosting with digital thermostat
- Manual night blind for energy saving
- PVC bumper for protection
- Equal airflow between the shelves
- Adjustable 5 line shelf
- Ral color choices
- Sliding door choices

CARACTERISTIQUES TECHNIQUES

- Moteur intégré
- Corps d'injection de polyuréthane 40kg/m³
- Indicateur digital avec thermostat et dégivrage programmable
- Base de vitrine en acier inoxydable 304
- Rideau de nuit manuel
- Protection avant en PVC
- 5 étagères
- Dispersion d'air égale entre toutes les étagères
- Options de couleur RAL
- Application et disposition en bloc
- Eclairage sous-étagère (Optionnel)

ÖLÇÜLER

- 937 mm
- 1250 mm
- 1875 mm
- 2500 mm
- 2812 mm
- 3125 mm
- 3750 mm

JASMINE PLUG-IN 2050

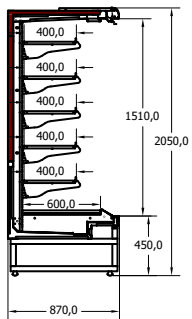

JASMINE PLUG-IN 2200

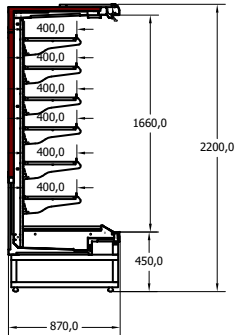

JASMINE PLUG-IN 2050

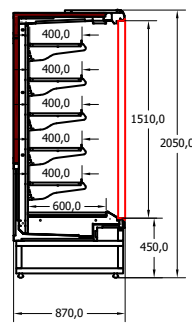

JASMINE PLUG-IN 2200

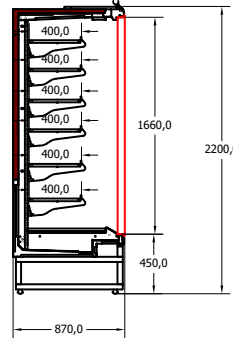



TEKNİK ÖZELLİKLER

- Dıştan motorlu
- 50kg/m³ poliüretan enjeksiyonlu gövde
- Dijital gösterge, termostatlı ve otomatik defrostlu
- PVC ön tampon koruyuculu
- 4 sıra raflı
- Bütün raflarda eşit hava dağılımı
- Ral seçenekleri
- Rezistanslı ithal alüminyum kapı ve çerçeveler
- Tel raflı

STANDARD FEATURES

- Remote wall case
- Air ventilated cooling system
- 50kg/m polyurethane injection body
- Programmable defrosting with digital thermostat
- PVC bumper for protection
- Equal airflow between the shelves
- Adjustable 4 shelf
- Ral color choices
- Heated matt aluminium frame doors
- Wire shelves

CARACTERISTIQUES TECHNIQUES

- Moteur à distance
- Corps d'injection de polyuréthane 50kg/m³
- Indicateur digital avec thermostat et dégivrage programmable
- Rideau de nuit manuel
- Protection avant en PVC
- 4 étagères
- Dispersion d'air égale entre toutes les étagères
- Options de couleur RAL
- Portes et châssis en aluminium exporté et à résistance
- tagère unique

ÖLÇÜLER

- 937 mm
- 1250 mm
- 1875 mm
- 2500 mm
- 2812 mm
- 3125 mm
- 3750 mm

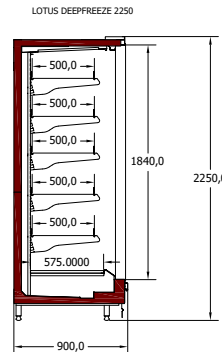
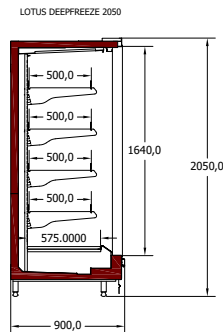

LUPİN MANAV REYONU

Soğutmalı Manav/ Refrigerated Greengrocer



TEKNİK ÖZELLİKLER

- Dıştan motorlu
- 40kg/m³ poliüretan enjeksiyonlu gövde
- Dijital gösterge, termostatlı ve otomatik defrostlu
- Paslanmaz çelik teşhir tavalı
- İthal gece perdeli
- PVC ön tampon koruyuculu
- 2 sıra raflı
- Bütün raflarda eşit hava dağılımı
- Ral seçenekleri
- Raf altı aydınlatması (opsiyonel)
- Ürün yansıtıcı aynalı

STANDARD FEATURES

- Remote wall case
- Air ventilated cooling system
- 40kg/m polyurethane injection body
- Stainless steel display
- Programmable defrosting with digital thermostat
- Manual night blind for energy saving
- PVC bumper for protection
- Equal airflow between the shelves
- Adjustable 2 shelf
- Ral color choices

CARACTERISTIQUES TECHNIQUES

- Corps d'injection de polyuréthane 40kg/m³
- Indicateur digital avec thermostat et dégivrage programmable
- Base de vitrine en acier inoxydable 304
- Rideau de nuit manuel
- Protection avant en PVC
- 2 étagères (la 3ème étagère est optionnelle)
- Dispersion d'air égale entre toutes les étagères
- Options de couleur RAL
- Application en bloc
- Eclairage sous-étagère (Optionnel)
- Miroir reflétant les produits

ÖLÇÜLER

- 937 mm
- 1250 mm
- 1875 mm
- 2500 mm
- 2812 mm
- 3125 mm
- 3750 mm

LUPİN 2050/100

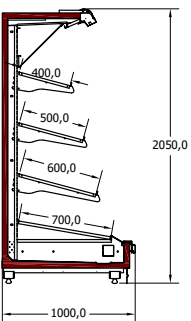

LUPİN 2200/100

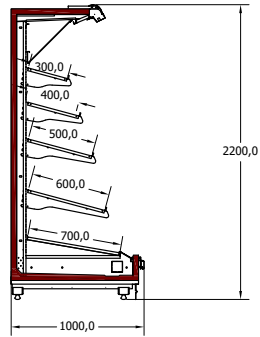

MAGNOLIA BOMBE CAMLI DEPOLU REYON

Et ve Şarküteri Vitrini / Deli and Meat Showcase



OPSİYONEL ÜRÜNLER

- Kağıtlık
- Kesme tahtası
- Bıçaklık
- Poşetlik
- Ara bölme camı

OPTIONS

- Stainless steel stands twolowel
- Cutting board
- Knife holder
- Holder plastic bags
- Divinding Glass

OPTIONS

- Porte-serviette
- Planche à découper
- Porte-couteaux
- Porte sacs plastiques
- Paroi de partition en verre

ÖLÇÜLER

- 625 mm
- 937 mm
- 1250 mm
- 1875 mm
- 2500 mm
- 2812 mm
- 3125 mm
- 3750 mm
- 1350 x 1350 köşe

TEKNİK ÖZELLİKLER

- Dıştan ve içten motor seçeneği
- Fan üfleli soğutma sistemi
- Otomatik defrost
- Dijital gösterge ve termostat
- 40kg/m poliüretan enjeksiyonlu gövde
- Poliüretan enjeksiyonlu yan paneller
- Amortisörlü yukarı doğru açılan sekurit camlar
- Paslanmaz çelik teşhir yüzeyi
- Paslanmaz çelik çalışma tezgahı
- Ayarlanabilen teşhir tavaları
- Buğulanma önleyici fan sistemi
- Dekorasyona uygun RAL renk seçenekleri
- Kapalı tip veya ayaklı dekor
- Paslanmaz 304 kalite
- Şarküteri - et - meze vitrini
- Led lamba

STANDARD FEATURES

- Remote or plug-in choices
- Air ventilated cooling system
- Programmable defrosting with digital thermostat
- 40kg/m polyurethane injection body
- Polyurethane injected side panels
- Tempered curved glass with lift-up system
- Stainless steel display
- Stainless steel working plate
- Adjustable display trays
- Anti-mist system for front glasses by ventilation
- Ral color choices
- Available with closed bottom trimor with legs
- Led light

CARACTERISTIQUES TECHNIQUES

- Option de moteur à distance ou intégré
- Système de refroidissement ventilé
- Dégivrage programmable
- Indicateur digital avec thermostat
- Corps d'injection de polyuréthane 40kg/m3
- Panneaux latéraux injectés en polyuréthane
- Verre trempé avec système de levage vertical
- Surface de vitrine en acier inoxydable 304
- Plaque de travail en acier inoxydable 304
- Plateaux de vitrine réglables
- Système de ventilation antibuée
- Choix de couleur Ral compatible avec la décoration
- Disponible avec coffre inférieure fermée ou sur piédestal
- Qualité d'acier inoxydable 304
- Vitrine réfrigérée de boucherie et de charcuterie
- Lumière LED

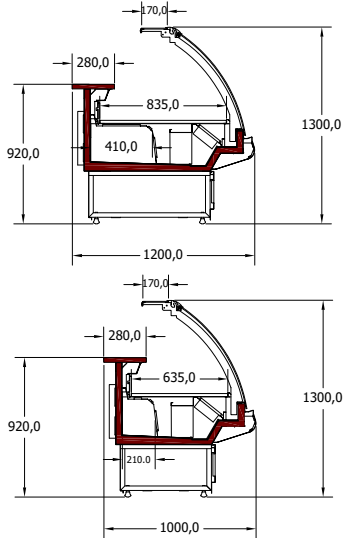

MAGNOLIA DİK CAMLI DEPOLU REYON

Et ve Şarküteri Vitrini / Deli and Meat Showcase



OPSİYONEL ÜRÜNLER

- Kağıtlık
- Kesme tahtası
- Bıçaklık
- Poşetlik
- Ara bölme camı

OPTIONS

- Stainless stell stands twolowel
- Cutting board
- Knife holder
- Holder plastic bags
- Divinding Glass

OPTIONS

- Porte-serviette
- Planche à découper
- Porte-couteaux
- Porte sacs plastiques
- Paroi de partition en verre

ÖLÇÜLER

- 625 mm
- 937 mm
- 1250 mm
- 1875 mm
- 2500 mm
- 2812 mm
- 3125 mm
- 3750 mm
- 1350 x 1350 köşe

TEKNİK ÖZELLİKLER

- Dıştan ve içten motor seçeneği
- Fan üfleli soğutma sistemi
- Otomatik defrost
- Dijital gösterge ve termostat
- 40kg/m poliüretan enjeksiyonlu gövde
- Poliüretan enjeksiyonlu yan paneller
- Amortisörlü yukarı doğru açılan sekurit camlar
- Paslanmaz çelik teşhir yüzeyi
- Paslanmaz çelik çalışma tezgahı
- Ayarlanabilen teşhir tavaları
- Buğulanma önleyici fan sistemi
- Dekorasyona uygun RAL renk seçenekleri
- Kapalı tip veya ayaklı dekor
- Paslanmaz 304 kalite
- Şarküteri - et - meze vitrini
- Led lamba

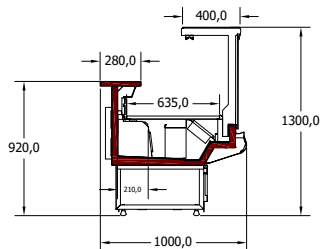
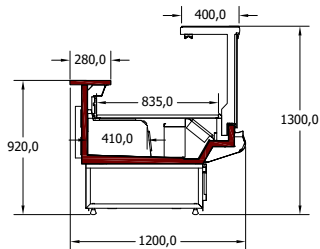

STANDARD FEATURES

- Remote or plug-in choices
- Air ventilated cooling system
- Programmable defrosting with digital thermostat
- 40kg/m polyurethane injection body
- Polyurethane injected side panels
- Tempered curved glass with lift-up system
- Stainless steel display
- Stainless steel working plate
- Adjustable display trays
- Anti-mist system for front glasses by ventilation
- Ral color choices
- Available with closed bottom trimor with legs
- Led light

CARACTERISTIQUES TECHNIQUES

- Option de moteur à distance ou intégré
- Système de refroidissement ventilé
- Dégivrage programmable
- Indicateur digital avec thermostat
- Corps d'injection de polyuréthane 40kg/m3
- Panneaux latéraux injectés en polyuréthane
- Verre trempé avec système de levage vertical
- Surface de vitrine en acier inoxydable 304
- Plaque de travail en acier inoxydable 304
- Plateaux de vitrine réglables
- Système de ventilation antibuée
- Choix de couleur Ral compatible avec la décoration
- Disponible avec coffre inférieure fermée ou sur piédestal
- Qualité d'acier inoxydable 304
- Vitrine réfrigérée de boucherie et de charcuterie
- Lumière LED

LILAC BOMBE CAMLI DEPOLU REYON “ARKA SÜRGÜ ÇERÇEVELİ” Et ve Şarküteri Vitrini / Deli and Meat Showcase



OPSİYONEL ÜRÜNLER

- Kağıtlık
- Kesme tahtası
- Bıçaklık
- Poşetlik
- Ara bölme camı

OPTIONS

- Stainless steel stands twolowel
- Cutting board
- Knife holder
- Holder plastic bags
- Divinding Glass

OPTIONS

- Porte-serviette
- Planche à découper
- Porte-couteaux
- Porte sacs plastiques
- Paroi de partition en verre

ÖLÇÜLER

- 625 mm
- 937 mm
- 1250 mm
- 1875 mm
- 2500 mm
- 2812 mm
- 3125 mm
- 3750 mm
- 1350 x 1350 köşe

TEKNİK ÖZELLİKLER

- Dıştan ve içten motor seçeneği
- Fan üfleli soğutma sistemi
- Otomatik defrost
- Dijital gösterge ve termostat
- 40kg/m poliüretan enjeksiyonlu gövde
- Poliüretan enjeksiyonlu yan paneller
- Amortisörlü yukarı doğru açılan sekurit camlar
- Paslanmaz çelik teşhir yüzeyi
- Paslanmaz çelik çalışma tezgahı
- Ayarlanabilen teşhir tavaları
- Buğulanma önleyici fan sistemi
- Dekorasyona uygun RAL renk seçenekleri
- Kapalı tip veya ayaklı dekor
- Paslanmaz 304 kalite
- Şarküteri - et - meze vitrini
- Led lamba

STANDARD FEATURES

- Remote or plug-in choices
- Air ventilated cooling system
- Programmable defrosting with digital thermostat
- 40kg/m polyurethane injection body
- Polyurethane injected side panels
- Tempered curved glass with lift-up system
- Stainless steel display
- Stainless steel working plate
- Adjustable display trays
- Anti-mist system for front glasses by ventilation
- Ral color choices
- Available with closed bottom trimor with legs
- Led light

CARACTERISTIQUES TECHNIQUES

- Option de moteur à distance ou intégré
- Système de refroidissement ventilé
- Dégivrage programmable
- Indicateur digital avec thermostat
- Corps d'injection de polyuréthane 40kg/m3
- Panneaux latéraux injectés en polyuréthane
- Verre trempé avec système de levage vertical
- Surface de vitrine en acier inoxydable 304
- Plaque de travail en acier inoxydable 304
- Plateaux de vitrine réglables
- Système de ventilation antibuée
- Choix de couleur Ral compatible avec la décoration
- Disponible avec coffre inférieure fermée ou sur piédestal
- Qualité d'acier inoxydable 304
- Vitrine réfrigérée de boucherie et de charcuterie
- Lumière LED

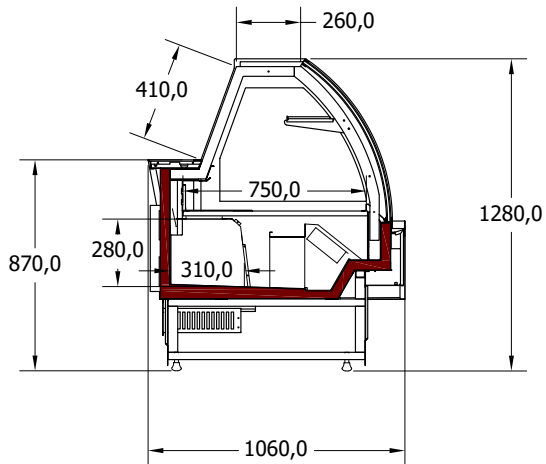

BREEZE HAVUZ REYONU

Soğutmalı Teşhir / Refrigerated Display



TEKNİK ÖZELLİKLER

- İçten motorlu promosyon dolabı
- Üfleli soğutma sistemi
- 28 cm yükseklik en geniş iç hacim
- Poliüretan enjeksiyon gövde
- Paslanmaz çelik koruyucu tampon
- Paslanmaz çelik iç teşhir yüzeyi

STANDARD FEATURES

- Plug-in cabinet
- Air frost cooling system
- Programmable defrosting with digital thermostat
- Polyurethane injected body
- Stainless steel bumper and decor
- Display surfaces in stainless steel

CARACTERISTIQUES TECHNIQUES

- Vitrine Réfrigérée à moteur intégré pour produits de promotion
- Système de refroidissement à air
- Volume intérieur très large avec ue hauteur de 28 cm
- Corps d'injection de polyuréthane
- Tampon de protection en acier inoxydable
- Base de présentation en acier inoxydable

ÖLÇÜLER

- 1020 mm
- 1330 mm
- 1955 mm

BREEZE 80

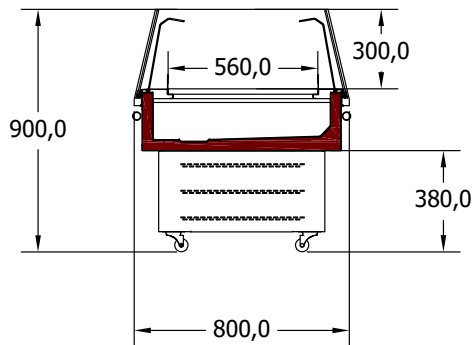

BREEZE 100

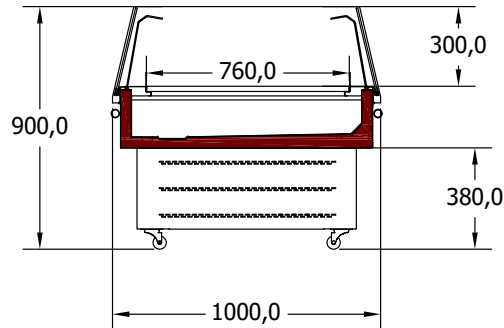



TEKNİK ÖZELLİKLER

- İçten motorlu promosyon dolabı
- Üfleli soğutma sistemi
- 28 cm yükseklik en geniş iç hacim
- Poliüretan enjeksiyon gövde
- Paslanmaz çelik koruyucu tampon
- Paslanmaz çelik iç teşhir yüzeyi

STANDARD FEATURES

- Plug-in cabinet
- Air frost cooling system
- Programmable defrosting with digital thermostat
- Polyurethane injected body
- Stainless steel bumper and decor
- Display surfaces in stainless steel

CARACTERISTIQUES TECHNIQUES

- Vitrine Réfrigérée à moteur intégré pour produits de promotion
- Système de refroidissement à air
- Volume intérieur très large avec une hauteur de 28 cm
- Corps d'injection de polyuréthane
- Tampon de protection en acier inoxydable
- Base de présentation en acier inoxydable

ÖLÇÜLER

- 1020 mm
- 1330 mm
- 1955 mm

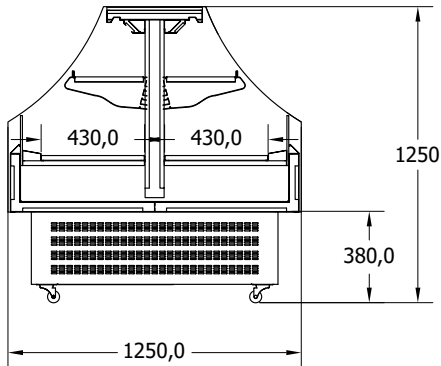

TULIP PLUG_IN KISA SÜTLÜK

Soğutmalı Teşhir / Refrigerated Display



TEKNİK ÖZELLİKLER

- İçten motorlu
- 2 sıra raflı
- Gece perdesi
- Su buharlaştırma sistemi
- Ral renk seçenekleri
- Çift camlı yan panel

STANDARD FEATURES

- Plug-in unit
- 2 row shelf
- Hydrolic night blind
- Multiplexible
- Water evaporation kit
- Double glass side panel
- Ral color

CARACTERISTIQUES TECHNIQUES

- Moteur intégré
- 2 étagères
- Rideau de nuit
- Système de vaporisation d'eau
- Options de couleur RAL
- Panneau latéral à double vitre

ÖLÇÜLER

- 1250 mm
- 1875 mm
- 2500 mm
- 2813 mm
- 3124 mm
- 3750 mm

TULIP İÇ MONTAJ

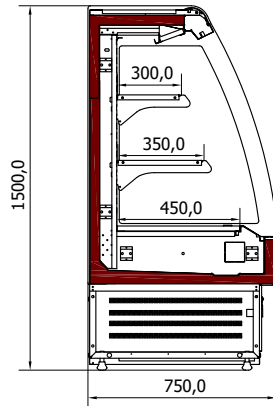



TEKNİK ÖZELLİKLER

- Dıştan motorlu
- 40kg/m³ poliüretan enjeksiyonlu gövde
- Dijital gösterge, termostatlı ve otomatik defrostlu
- Paslanmaz çelik teşhir tavalı
- İthal gece perdeli
- PVC ön tampon koruyuculu
- 4 sıra raflı
- Bütün raflarda eşit hava dağılımı
- Ral seçenekleri
- Ada uygulaması
- Raf altı aydınlatması (opsiyonel)
- İthal alüminyum kapı ve çerçeveler

STANDARD FEATURES

- Remote wall case
- Air ventilated cooling system
- 40kg/m polyurethane injection body
- Stainless steel display
- Programmable defrosting with digital thermostat
- Manual night blind for energy saving
- PVC bumper for protection
- Equal airflow between the shelves
- Adjustable 4 shelf
- Ral color choices
- Matt aluminium frame doors

CARACTERISTIQUES TECHNIQUES

- Moteur à distance ou moteur intégré
- Corps d'injection de polyuréthane 40kg/m³
- Indicateur digital avec thermostat et
- dégivrage programmable
- Base de vitrine en acier inoxydable 304
- Rideau de nuit manuel
- Protection avant en PVC
- 5 étagères
- Dispersion d'air égale entre toutes les étagères
- Options de couleur RAL
- Application et disposition en bloc
- Eclairage sous-étagère (Optionnel)

ÖLÇÜLER

- 2D / 1560 mm
- 3D / 2340 mm
- 4D / 3120 mm
- 5D / 3900 mm

JASMINE 2200/90

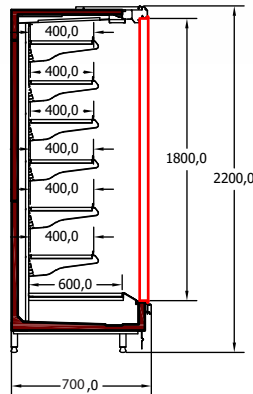

JASMINE 2050/90

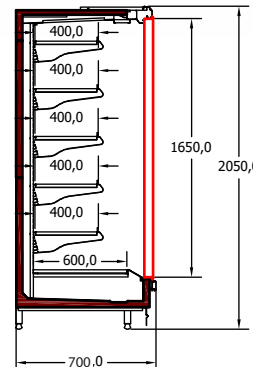

MISTRAL İKİLİ DERİN DONDURUCU PLUG-IN

Duvar Tipi Derin Dondurucu / Vertical Type Deep Freezer



TEKNİK ÖZELLİKLER

- İçten motorlu
- 50kg/m³ poliüretan enjeksiyonlu gövde
- Dijital gösterge, termostatlı ve otomatik defrostlu
- PVC ön tampon koruyuculu
- 2 sıra raflı
- Bütün raflarda eşit hava dağılımı
- Ral seçenekleri
- Rezistanslı ithal alüminyum kapı ve çerçeveler
- Tel raflı
- -18°C / -22°C

STANDARD FEATURES

- Plug-in
- Air ventilated cooling system
- 50kg/m polyurethane injection body
- Programmable defrosting with digital thermostat
- PVC bumper for protection
- Equal airflow between the shelves
- Adjustable 2 shelf
- Ral color choices
- Heated matt aluminium frame doors
- Wire shelves
- -18°C / -22°C

CARACTERISTIQUES TECHNIQUES

- Moteur à board
- Corps d'injection de polyuréthane 50kg/m³
- Indicateur digital avec thermostat et dégivrage programmable
- Rideau de nuit manuel
- Protection avant en PVC
- 2 étagères
- Dispersion d'air égale entre toutes les étagères
- Options de couleur RAL
- Portes et châssis en aluminium exporté et à résistance
- tagère unique
- -18°C / -22°C

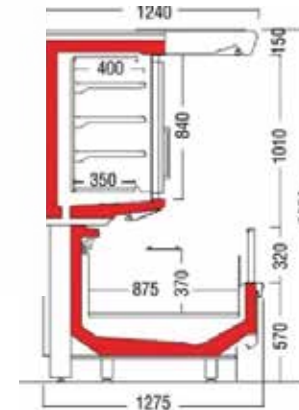

MISTRAL İKİLİ DERİN DONDURUCU

Duvar Tipi Derin Dondurucu / Vertical Type Deep Freezer



TEKNİK ÖZELLİKLER

- -18/-22C çalışma sıcaklığı
- Dıştan motorlu
- 2 sıra raflı
- Ayarlanabilir tel raflı
- Pvc koruma tamponu
- Poliüretan gövde
- Dijital termostat
- Evaporatör exp. vals

STANDARD FEATURES

- -18/-22C working temperature
- Remote condensing unit
- 2 adjustable wire shelf
- Pvc bumper
- Air frost system
- Polyurethane injection body
- Digital thermostat
- Evap with exp. valve

OPSİYONEL ÜRÜNLER

- Tel ızgara ve ara bölücüler
- Gece perdesi
- Sürgü cam kapama

OPTIONS

- Wire divider and tray
- Slow rise night blind
- Sliding glass door

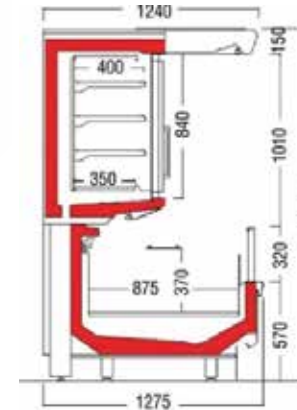

GUST TEK PARÇA DERİN DONDURUCU

Yatay Tip Derin Dondurucular / Horizontal Show Case Freezer



TEKNİK ÖZELLİKLER

- Dıştan motorlu yatay reyon
- Poliüretan gövde
- Çift evaporatör exp. valf ile tampon
- Dijital termostat
- Air-frost sistem
- Gondol başı uygulaması

OPSIYONEL ÜRÜNLER

- Tel ızgara ve ara bölücüler
- Gece perdesi
- Sürgü cam kapama

STANDARD FEATURES

- Remote control unit
- Polyurethane body
- Double evaporator exp. with valf
- Bumper
- Dijital termostat
- Air-frost system
- Head cabinet option

OPTIONS

- Wire divider and tray
- Slow rise night blind
- Sliding glass door

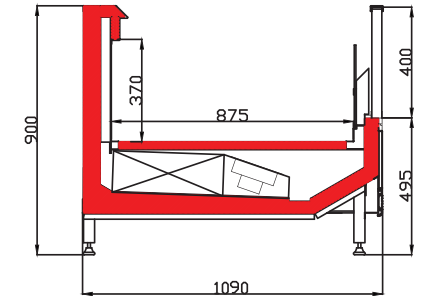
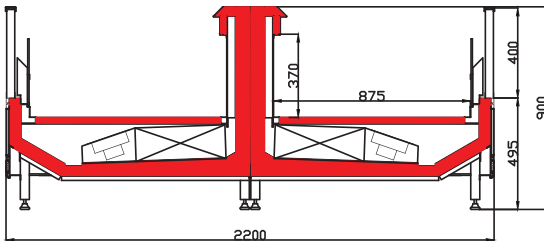

Yatay Derin Dondurucu / Horizontal Deepfreezer



TEKNİK ÖZELLİKLER

- Dıştan motorlu yatay reyon
- Poliüretan gövde
- Çift evaporatör exp. valf ile tampon
- Dijital termostat
- Air-frost sistem
- Gondol başı uygulaması

OPSİYONEL ÜRÜNLER

- Tel ızgara ve ara bölücüler
- Gece perdesi
- Sürgü cam kapama

STANDARD FEATURES

- Remote control unit
- Polyurethane body
- Double evaporator exp. with valf
- Bumper
- Digital termostat
- Air-frost sistem
- Head cabinet option

OPTIONS

- Wire divider and tray
- Slow rise night blind
- Sliding glass door

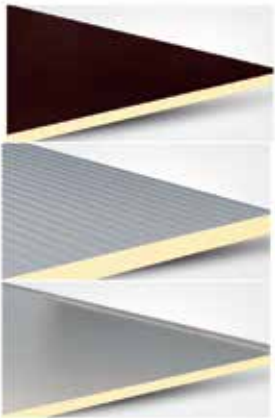
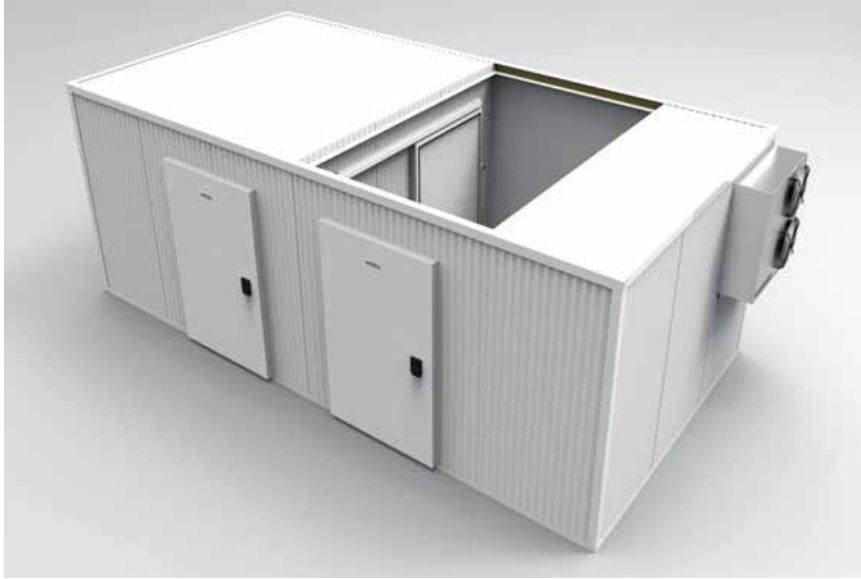



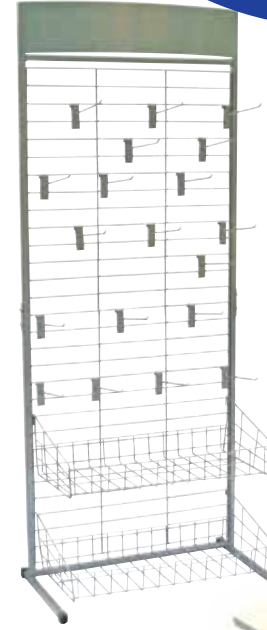



MERKEZİ SİSTEM SOĞUTMA GRUBU

Central System Cooling Group





RAL

RENKLER / COLORS

				
RAL 1013	RAL 1015	RAL 1018	RAL 1023	RAL 1028
				
RAL 2003	RAL 2004	RAL 2008	RAL 3000	RAL 3003
				
RAL 3004	RAL 3020	RAL 5002	RAL 5005	RAL 5010
				
RAL 5015	RAL 5018	RAL 6018	RAL 6019	RAL 6029
				
RAL 7015	RAL 7016	RAL 7021	RAL 7024	RAL 8024
				
RAL 9003	RAL 9005	RAL 9006	RAL 9010	RAL 9016



İstanbul Fabrika

Eyüp Sultan Mah. İmam Rabbani Cad. No: 42/2
Yanyol Samandıra / Sancaktepe / İstanbul / TÜRKİYE
Tel: +90 (216) 561 60 75
Fax: +90 (216) 561 71 23
www.seckinsogutma.com

France Bureau

1317 Rue des Chartinieres 01120 Dagneux
Lyon / FRANCE
Mobile: 0033 6 35 25 58 00
www.seckinsogutma.com